

Experiment I: Vectors

Goals

- Practice resolution of vectors into their components and addition of vectors
- Visualize these processes on a force table

Introduction and Background

One of the most important concepts in physics is the concept of vector quantities, such as velocity, acceleration and force. It is essential that you understand the concept of vector, the addition of vectors, and the resolution of a vector into its components. This lab is designed to give you exercises in performing these processes and help you visualize them on a force table. The diagram below illustrates the resolution of a vector \mathbf{F} into x - and y -component relative to a given choice of x - y coordinate system:

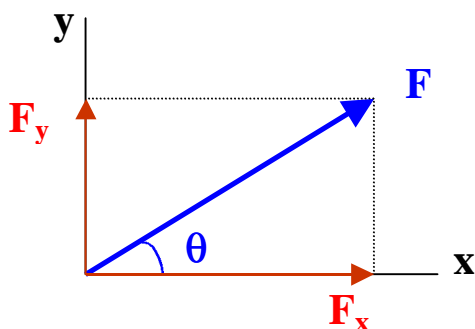

$$F_x = F \cos\theta$$

$$F_y = F \sin\theta$$

$$\tan\theta = F_y / F_x$$

$$F = \sqrt{F_x^2 + F_y^2}$$

Figure 1-1: Resolving a vector into its components

There are two common methods for finding the resultant of many vector quantities: the first is the graphic method (parallelogram or tail-to-tip, see your textbook for details); the mathematically precise method is by adding components in which each vector is first resolved into its x - and y -components, the total x - and y -components are then obtained from the algebraic sum of all the x - and y -components:

$$F_x = F_{x1} + F_{x2} + F_{x3} + \dots$$

$$F_y = F_{y1} + F_{y2} + F_{y3} + \dots$$

Since we are dealing with algebraic sums, it is important to keep track of the signs of each component.

In this lab we will use the weight of objects (one type of force) as a representative vector to study the addition of vectors. We will make use of the condition for static equilibrium: the vector sum of all the forces acting on a body at rest is zero. We will calculate the resultant of a number of forces, $\mathbf{F}_R = \mathbf{F}_1 + \mathbf{F}_2 + \mathbf{F}_3 + \dots$, and place on the force table the negative of the resultant force, $-\mathbf{F}_R$, to verify the calculation. If the calculation is correct, this should result in a static equilibrium.

Experimental Setup

Equipment: Force table, pulley, weights and hangers, ruler, polar graph paper

Setup: Figure 1-2 shows a schematic drawing of the experimental setup. Weight (force of gravity) always points downward. We use a pulley mounted on the edge of the force table to turn it into a horizontal force with the same magnitude. The table is marked in 1° intervals, and the forces on the ring are directed along the strings outward. The weight can be calculated from the mass using the relationship: $W = mg$, where m is the mass. *Note that you must include the weight of the hanger as part of the force.*

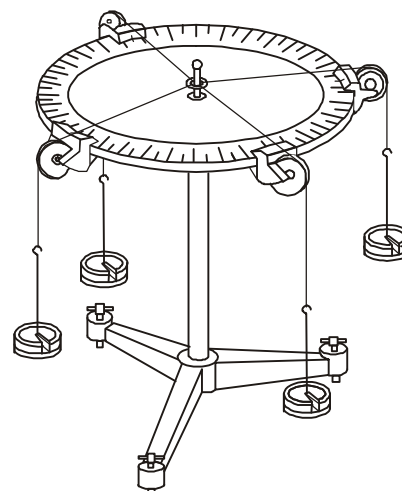

Figure 1.2 – Force table.

Experimental Procedure

For each part of the experiment draw a vector diagram *to scale* on a piece of polar graph paper.

1. (a) Hang a 0.20 kg mass at 110° . Calculate the weight of the mass.

Hang a second mass so that the ring is in equilibrium. What is the direction (in degrees) and magnitude of this balancing force?

(b) Calculate the x - and y -components of the force at 110° in Part 1(a) for a x - y coordinate system with the positive x -axis at 0° and the y -axis at 90° . Replace this force by its x - and y -components on the force table while leaving the balancing force unchanged. Is the ring still in equilibrium?

(c) Calculate the x - and y -components of the force at 110° in Part 1(a) for a x - y coordinate system with the positive x -axis at 70° . At what angle on the force table is the y -axis now? Replace the original force at 110° by these new x - and y -components on the force table while leaving the balancing force unchanged. Do the components of a vector depend on your choice of the coordinate system?

2. Mount a pulley at 20° and suspend a 0.98 N weight from the string; mount another pulley at 140° and suspend a 1.96 N weight from it. Draw a vector diagram to scale and find the resultant force graphically by the parallelogram method. Determine both the magnitude and direction of the resultant.

For a more accurate result, find the resultant from the components with the x -axis at 0° . Calculate both the magnitude and direction of the resultant. Set up the *negative* of the resultant force (equal in magnitude but 180° away in direction), in addition to the two forces already on the force table. Is the ring in equilibrium?

3. Set up the pulleys at 20° and 140° as in Part 2, using the same weights. Mount a third pulley at 220° and suspend 1.47 N over it. Calculate the resultant of the three forces using components with the x -axis at 0° . Set up the negative of the resultant and check for equilibrium.

Discussions and Questions

In the context of the results you have obtained, discuss the following:

1. Are the components of a vector unique?
2. Are the components of a vector equivalent in their effect to the force itself?
3. Does the order in which you add two or more vectors affect the resultant of the vectors?

Conclusions

Briefly discuss whether you have accomplished the goals listed at the beginning.